

**Serie | 2, built-under cooker hood, 60 cm, Stainless steel
DUL62FA51**



The built-under cooker hood: save space by mounting the hood beneath your upper cabinet or on the wall.

- **LED-Illumination:** The energy-saving lighting provides white and good lighting for the hob area.
- With exhaust, the air is cleaned by a grease filter and then ducted to the outside which ensures optimal kitchen air quality.

Technical Data

Typology : Built-in/Built-under
 Approval certificates : CE, Ukraine
 Length electrical supply cord : 145 cm
 Net weight : 6.2 kg
 Type of control : mechanical
 Number of speed settings : 3
 Maximum output air extraction : 250 m³/h
 Maximum output recirculating air : 80 m³/h
 Number of lights : 1
 Noise level : 68 dB(A) re 1 pW
 Diameter of air outlet : 100 / 120 mm
 Grease filter material : Not washable synthetic
 Odour filter : No
 Operating Mode : Convertible
 Optional accessories : DHZ2701, DHZ1620, DHZ2140
 Total power of the lamps : 4 W
 Grease filter type : Multilayer
 Connection Rating : 119 W
 Voltage : 220-240 V
 Frequency : 50 Hz
 Plug type : Gardy plug w/ earthing
 Installation typology : Built-under
 Material body : Stainless steel
 Approval certificates : CE, Ukraine
 Plug type : Gardy plug w/ earthing
 Dimensions of the product, with chimney (if exists) (in) : / x x
 Dimensions of the packed product : 10.62 x 29.13 x 25.59
 Net weight : 14.000 lbs
 Gross weight : 22.000 lbs
 Motor location : Integrated motor in hood body
 No-return airflow flap : Yes
 Length electrical supply cord : 145 cm
 Dimensions of the product, with chimney (if exists) : 150 x 600.0 x 482.0 mm
 Dimensions of the packed product (HxWxD) : 270 x 740 x 650 mm
 Net weight : 6.2 kg
 Gross weight : 9.8 kg



Serie | 2, built-under cooker hood, 60 cm, Stainless steel DUL62FA51

**The built-under cooker hood: save space
by mounting the hood beneath your upper
cabinet or on the wall.**

- Energy Efficiency Class: D (at a range of energy efficiency classes from A+++ to D)
- Average Energy Consumption: 69.3 kWh/year
- Blower Efficiency Class: E*
- Lighting Efficiency Class: E
- Grease Filtering Efficiency Class: D
- Noise min./max. Normal Level: 53/68 dB

Variant:

Design:

Technical information

Performance

Power:

Environment and safety:

Comfort:

Measures:

Technical information

- Built-under Hood Brushed steel
- For installation underneath a wall cupboard or on the wall
- Suitable for ducted or re-circulated extraction
- For recirculated extraction standard odor filter (accessory) needed
- Sliding switch control
- 3 speeds
- Single motor
- Paper grease filter
- Adjustable glass visor
- 1 x 4 W LED 4W E14
- Light Intensity: 45 lux
- Colour Temperature: 3000 K
- Extraction rate exhaust air according to EN 61591: max. 250 m³/h
- Noise level according to EN 60704-3 und EN 60704-2-13 at max. normal use exhaust air: 68 dB(A) re 1 pW (54 dB(A) re 20 µPa sound pressure)
- Max. extraction rate: 250 m³/h
- Dimensions (HxWxD): 150 x 600 x 482 mm
- 100 or 120 mm diameter pipe
- Power rating: 119 W
- with one-way flap

** In accordance with the EU-Regulation No 65/2014*

**Serie | 2, built-under cooker hood, 60 cm,
Stainless steel
DUL62FA51**

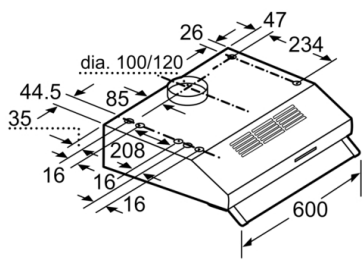

measurements in mm

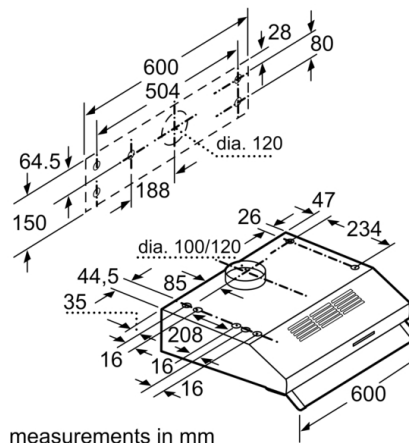

measurements in mm

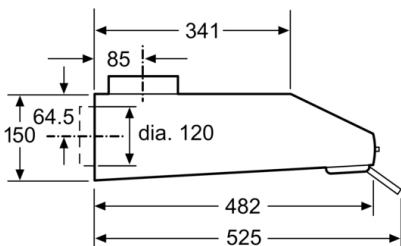

measurements in mm